



SPECIFICATIONS FOR GERSTUNG SUSPENDED FLOOR SYSTEM

A. The design: AIRBASE® 300

Single layered plywood subfloor to be suspended on 1-1/2" high Energy Blocks™, spaced to cover 2.41 blocks per square foot.

B. Specifications of component parts:

1. Energy Blocks™:

To consist of closed cell spring foam: Mill-R 6130 Ctype 2, grade B, medium to firm density 16 p.c.f., tensile strength 150 p.s.i., elongation 250%. Size 1-1/2" x 2 1/8" x 2 1/8" arranged to cover at least 2.41 blocks per square foot and adhered permanently to the underside of plywood. No cross linked polyethylene foam accepted. If other than "Gerstung" product, foam block compression test is required: maximum compression of 1/4" under 1,300 pounds distributed over 25 square feet area. After 168 hours permanent depression set is not to exceed 1/16th of an inch (2.15%).

2. Plywood:

Single layer of top grade plywood, Baltic or Finland Birch. Dimensions: 3'-11 1/4" x 3'-11 1/4", laminations should be 1/16th of an inch or less with an overall thickness of 12mm. Adjacent plywood sections shall be secured using our patented tongue and spring track



gerstung

FLOOR SYSTEMS

Quick Set .

Air Base[®] 300

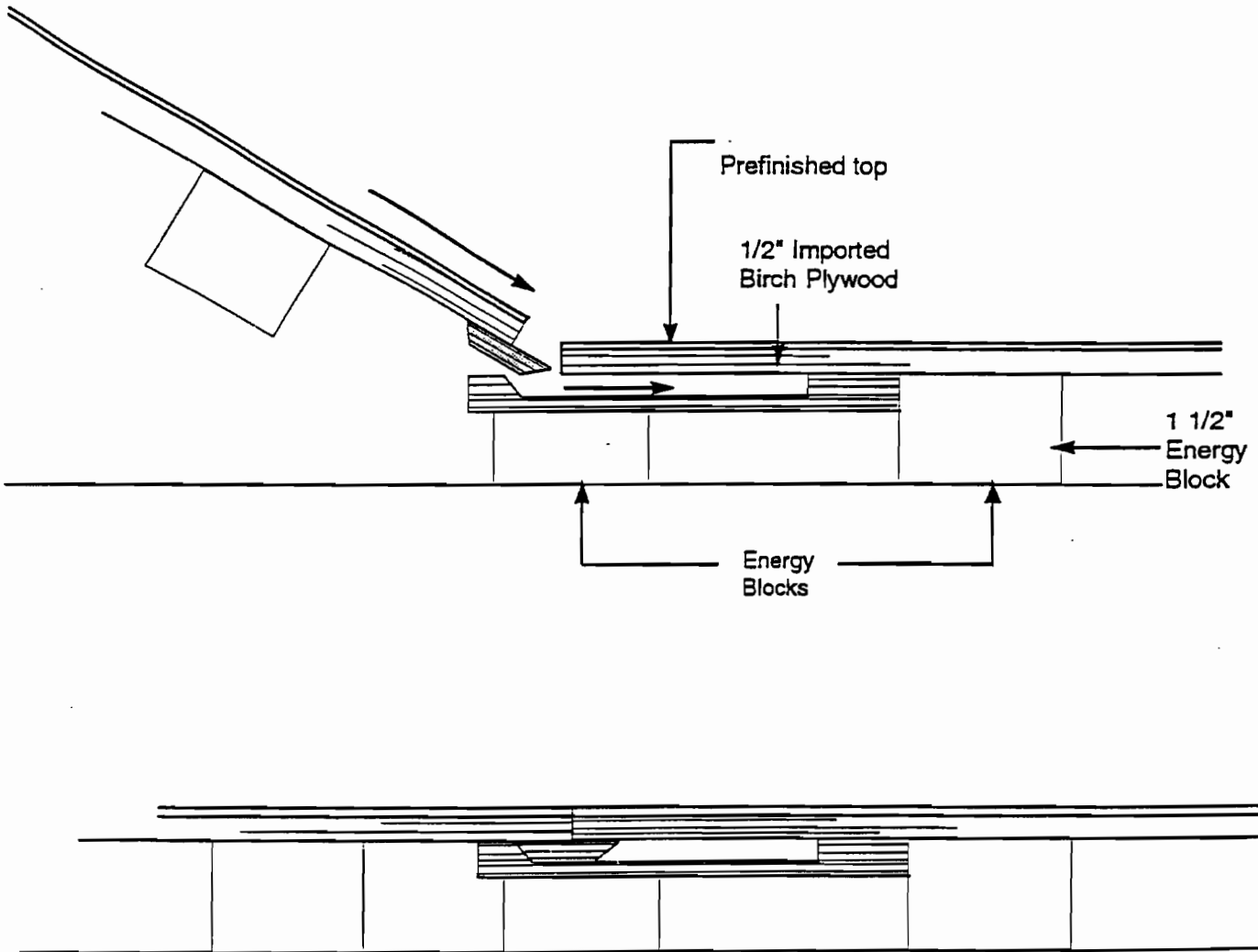

1400 COPPERMINE TERRACE BALTIMORE MD 21209-2012 U.S.A.

(410) 337-7781 FAX (410) 337-0471



gerstung

FLOOR SYSTEMS

QUICK SET™/ AIRBASE® 300 and AEROBICS COMPETITION FLOOR 301

Setup Instructions

Our Quick Set™ design is developed for quick setups and take downs without tools. Each panel is equipped with a "spring track" on two sides and a "tongue" on the other two sides. Each side interlocks with the opposite side of the next panel.

A: Build the floor one row at a time.

1. Select placement of the first row by measuring layout of the entire floor.
2. Put the first section in the corner of your proposed floor with both tongue sides facing outside. Allow for border/ ramp space.
3. Place a second panel, turned the same way as panel one, with the tongue edge into spring track of the corner panel.
4. With panel #2 at an angle of approximately 45 degrees (about hip height) the tongue should slide and saddle into the track of the previous panel. Make the necessary adjustments so both panels line up perfectly before lowering the panel with slight forward pressure.
5. Do not lower panel all the way until you are sure the tongue is fully engaged in the spring track.
6. Repeat steps 3 & 4 until the entire row is completed.

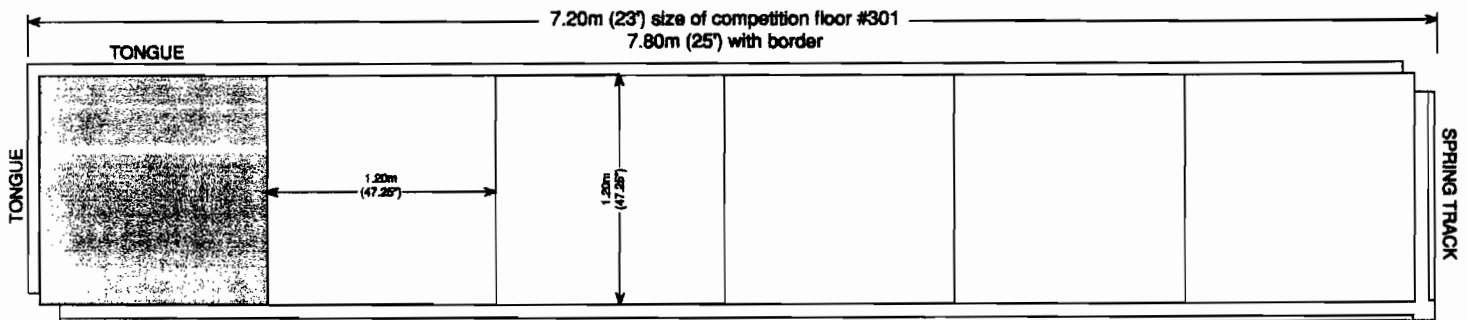
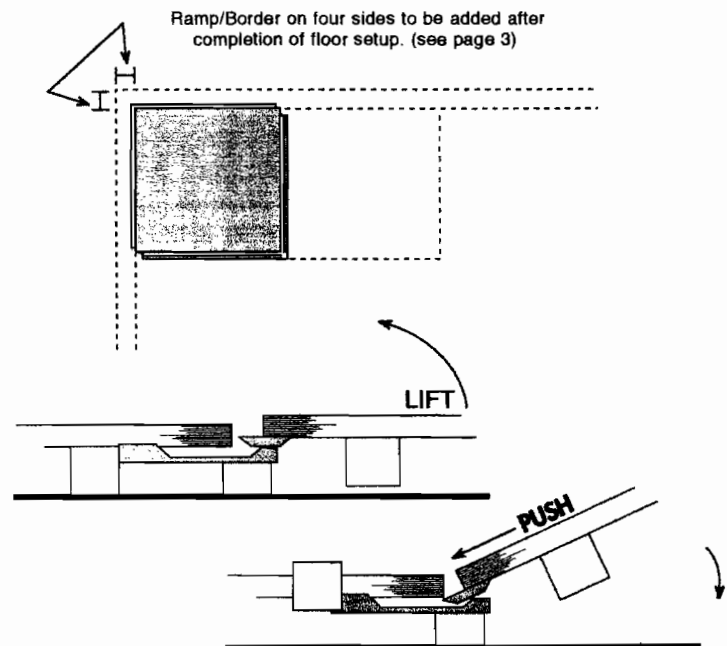
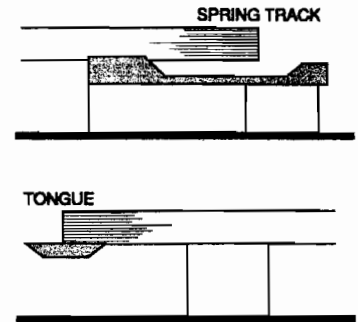
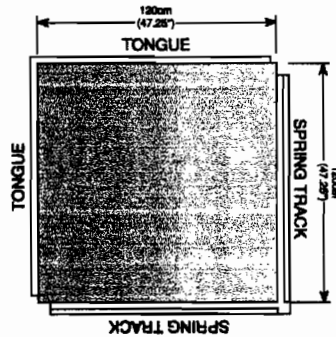



B: Each row is constructed in exactly the same way.

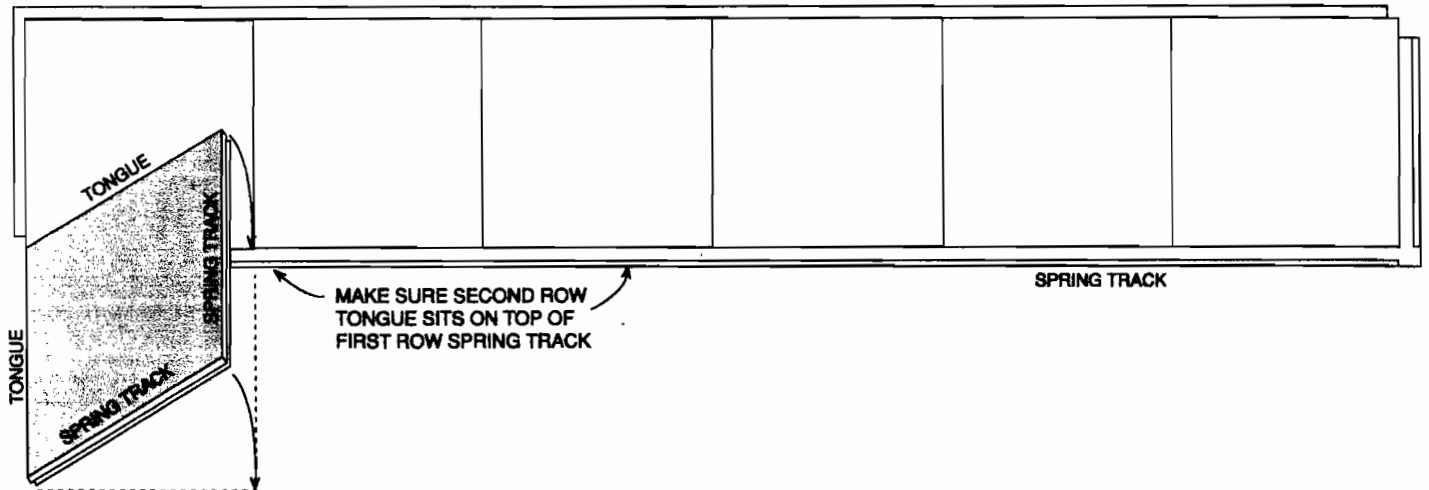

IMPORTANT:

1. Place first panel of second row in the same direction as all others with the tongue placed on top of the spring edge of the previous row but without connecting it to the existing floor strip.
 2. Connect second and all other panels in perfect alignment to each other. The entire panel strip must lay with its tongue on top of the spring track of the existing floor strip.
 3. The entire panel row should now be connected to the floor strip. At least one person for every 1 1/2 to 2 panels is necessary in order to lift an entire row. For six panels, three to four people are necessary. They must be equally spaced along the edge that is to be lifted.
 4. On the command "Lift" everyone simultaneously picks up the entire row about hip high as the tongue slides into the spring track.
 5. Move entire row to the left or right until all corners of the floor pattern are perfectly aligned.
 6. Lower the entire row as one unit slowly and evenly. Push forward, especially when sections are at knee height, allowing interlocking to take place. If this does not occur immediately the entire row must be lifted up again and pushed forward before it can be lowered to the ground again.
- WARNING:** Problems can occur if a row of sections is lifted unevenly. This causes the connecting edge to twist, breaking the connection to the spring track of the existing floor strip.
7. Repeat all steps until entire floor is completed.

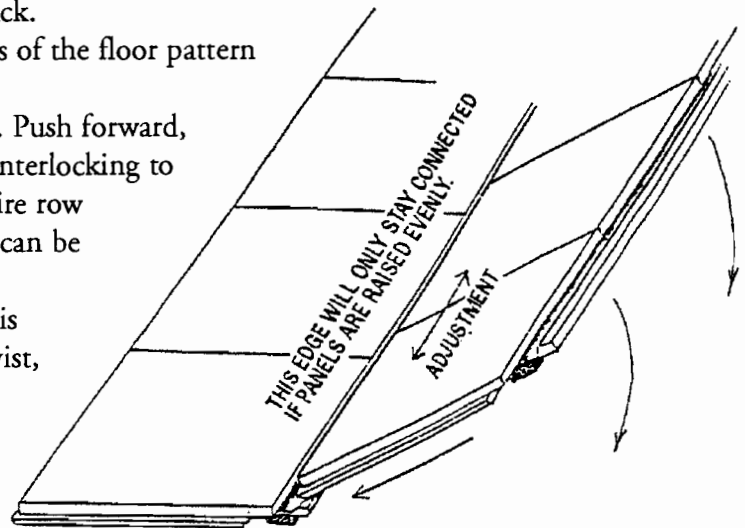



gerstung

FLOOR SYSTEMS

C: To complete your floor:

1. Depending on your specific purchase you will have ramps and/or borders. Attach ramps/borders on all four sides of the floor. Tongue to spring track and push spring track of ramp/border sections underneath of tongue edge. (A panel may have to be lifted slightly.)
2. You should have ramps/borders that are longer than others. They are used for corners.

If you purchase a floor that has a combination of borders, ramps, or no edge we will provide you with additional information.

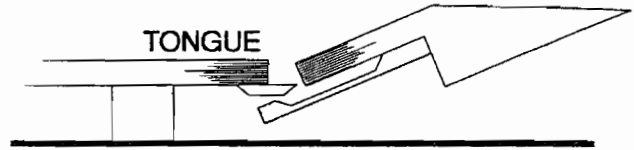

Important:

Storage

Panels are seldom damaged when in use. The tongue and spring track, as well as foam blocks, are damaged from poor handling, storage, and transportation.

1. Panels should only be stored on the smaller spring track edge. The tongue has an edge that breaks easily.
2. Never stack panels or store them on top of each other – it crushes the foam blocks on the bottom.
3. Store and transport Airbase® sections only in specially designed transporters that are made for storage and transportation (see illustration, they go on the transporter only one way!). If this is not available, store panels on spring track edge at not more than a 10° angle. A wider angle will also cause a permanent depression of the foam blocks.
4. Keep panels out of moist areas and away from direct sun or heat source. Wood will warp when exposed to moisture and dry out (crack) when exposed to extreme heat and dryness. Use common sense!

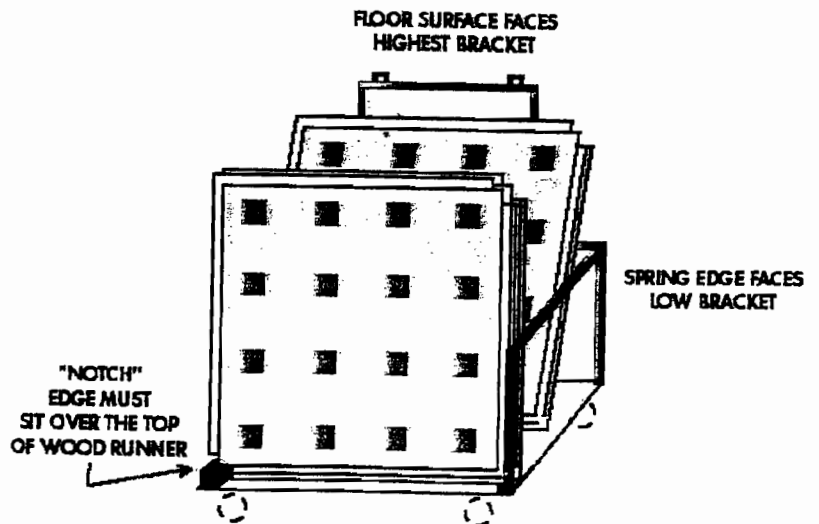
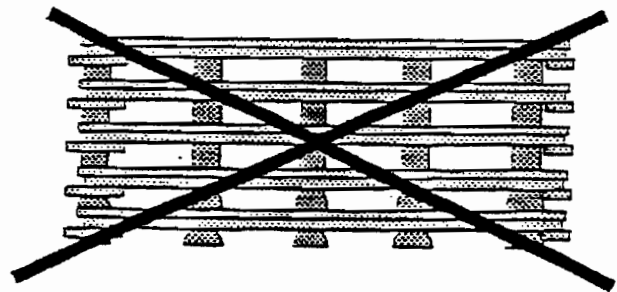

If you have questions about setting up your floor, call Gerstung at 800-922-3575



gerstung

FLOOR SYSTEMS

Airbase[®] Transporter

EASY TO TRANSPORT

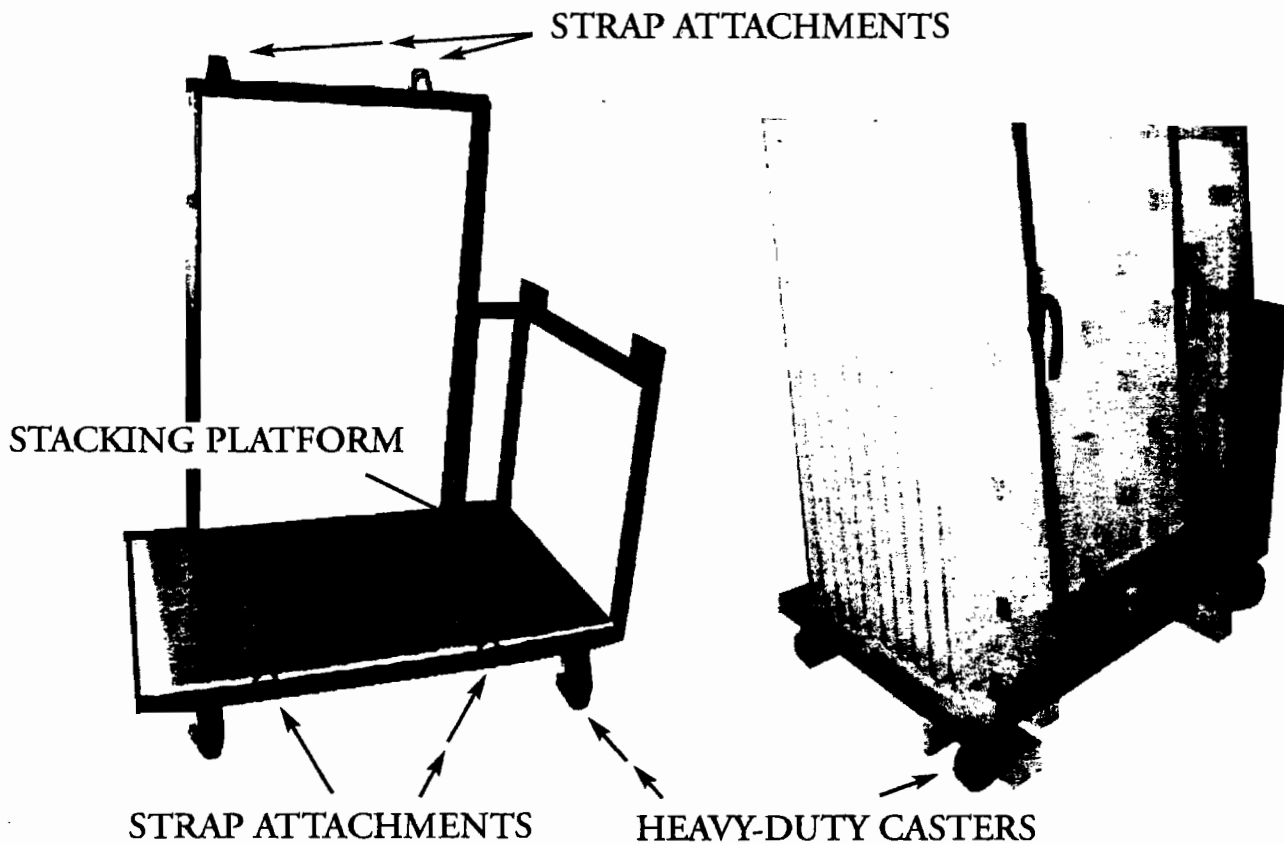

The Gerstung Airbase[®] Transporter is manufactured of tubular steel and strong angle iron welded to achieve stability. Each unit is equipped with heavy duty casters. The stacking platform consists of plywood lined with Flex Tred for safe vertical stacking of panels. The heavy duty seat belt straps keeps the panels secured on the transporter.